

GB

Operating manual

TITAN™
Advanced Performance. Total Reliability.

Performance Series 1150e

Airless high-pressure spraying unit

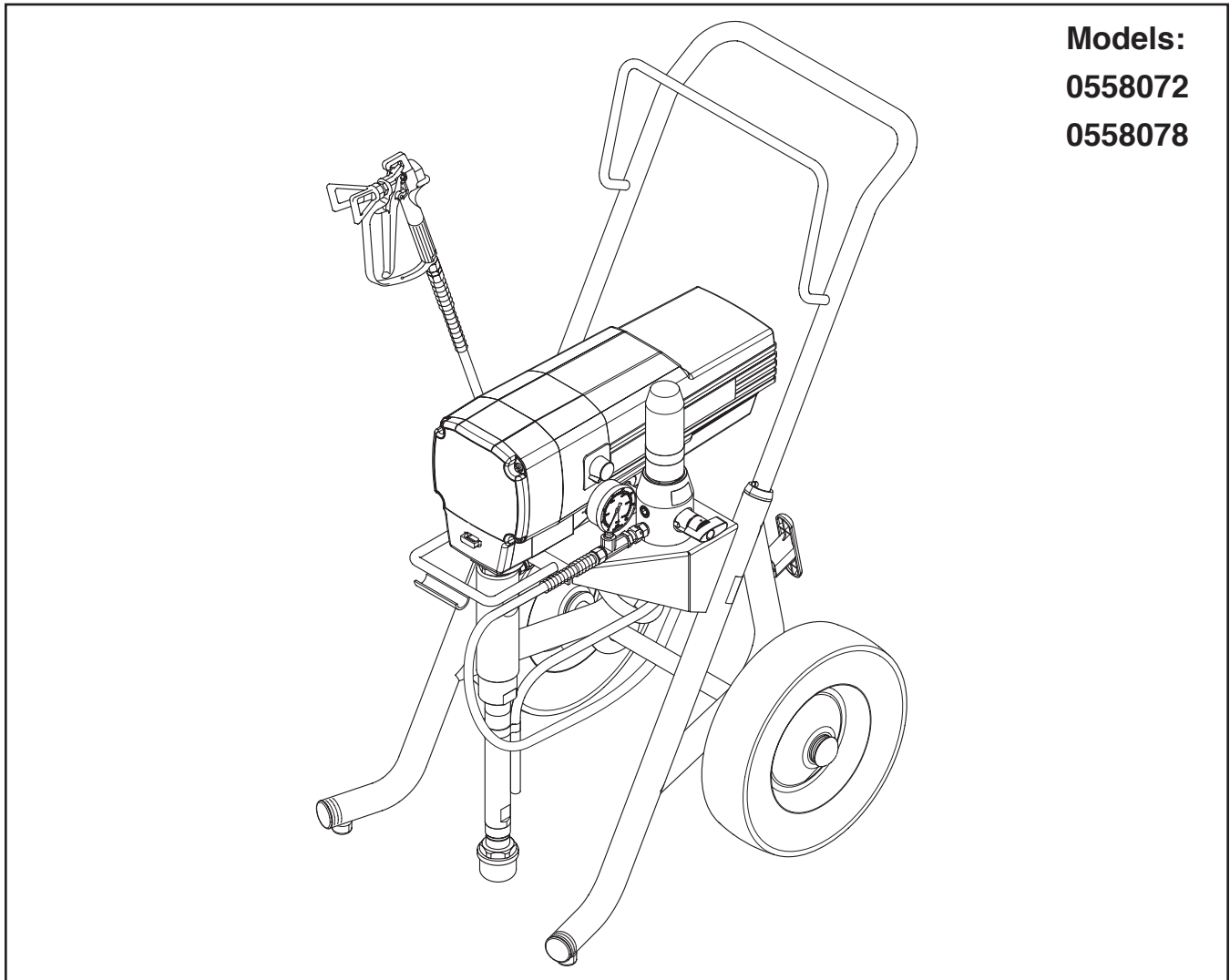

Models:
0558072
0558078

Performance Series 1150e

Warning!

Attention: Danger of injury by injection!

Airless units develop extremely high spraying pressures.

1

Never put your fingers, hands or any other parts of the body into the spray jet!



Never point the spray gun at yourself, other persons or animals. Never use the spray gun without safety guard.



Do not treat a spraying injury as a harmless cut. In case of injury to the skin through coating materials or solvents, consult a doctor immediately for quick and expert treatment. Inform the doctor about the coating material or solvent used.



2

The operating instructions state that the following points must always be observed before starting up.

1. Faulty units must not be used.
2. Secure Titan spray gun using the safety catch on the trigger.
3. Ensure that the unit is properly earthed. The connection must take place through a correctly earthed two-pole and earth socket outlet.
4. Check allowable operating pressure of high-pressure hose and spray gun.
5. Check all connections for leaks.



3

The instructions regarding regular cleaning and maintenance of the unit must be strictly observed.



Before any work is done on the unit or for every break in work the following rules must be observed:

1. Release the pressure from spray gun and hose.
2. Secure the Titan spray gun using the safety catch on the trigger
3. Switch off unit.



Be safety-conscious!

Contents

	Page		Page
1. Safety regulations for Airless spraying	4	9. Remedy in case of faults	13
1.1 Earthing instructions	5	10. Servicing	14
2. General view of application	6	10.1 General servicing	14
2.1 Application	6	10.2 High-pressure hose	14
2.2 Coating materials	6	11. Repairs at the unit	14
3. Description of unit	6	11.1 Relief valve	14
3.1 Airless process	6	11.2 Inlet and outlet valve	14
3.2 Functioning of the unit	6	11.3 Packings	15
3.3 Legend for explanatory diagram		11.4 Replacing the motor assembly	16
Performance Series 1150e	7	11.5 Replacing the gears	17
3.4 Explanatory diagram Performance Series 1150e	7	11.6 Replacing the transducer	18
3.5 Technical data	8	11.7 Performance Series 1150e connection diagram	19
3.6 Transportation	8	12. Accessories for Performance Series 1150e	20
3.7 Transportation in vehicle	8	13. Appendix	21
4. Starting operation	8	13.1 Selection of tip	21
4.1 High-pressure hose, spray gun and		13.2 Servicing and cleaning of Airless	
separating oil	8	hard-metal tips	21
4.2 Pressure control knob settings	8	Spare parts list for main assembly	22
4.3 Connection to the mains network	8	Spare parts list for drive assembly	24
4.4 Cleaning preserving agent when		Spare parts list for fluid section	26
starting-up of operation initially	8	Spare parts list for gear box assembly	28
4.5 Taking the unit into operation		Spare parts list for filter assembly	29
with coating material	9	Spare parts list for upright cart assembly	30
5. Spraying technique	10	Warranty	32
6. Handling the high-pressure hose	10		
6.1 High-pressure hose	10		
7. Interruption of work	10		
8. Cleaning the unit (shutting down)	11		
8.1 Cleaning unit from outside	11		
8.2 Cleaning the high-pressure filter	11		
8.3 Cleaning Airless spray gun	12		

1. Safety regulations for Airless spraying

This manual contains information that must be read and understood before using the equipment. When you come to an area that has one of the following symbols, pay particular attention and make certain to heed the safeguard.



This symbol indicates a potential hazard that may cause serious injury or loss of life. Important safety information will follow.



Attention

This symbol indicates a potential hazard to you or to the equipment. Important information that tells how to prevent damage to the equipment or how to avoid causes of minor injuries will follow.



A hazard symbol such as this one refers to a specific, task-related risk. Be sure to heed the safeguard.



Notes give important information which should be given special attention.

	<p>HAZARD: INJECTION INJURY A high pressure stream produced by this equipment can pierce the skin and underlying tissues, leading to serious injury and possible amputation.</p> <p>DO NOT TREAT AN INJECTION INJURY AS A SIMPLE CUT! Injection can lead to amputation. See a physician immediately.</p> <p>The maximum operating range of the unit is 214 bar (21.4 MPa, 3100 PSI) fluid pressure.</p>
	<p>PREVENTION:</p>
	<ul style="list-style-type: none"> • NEVER aim the gun at any part of the body. • NEVER allow any part of the body to touch the fluid stream. DO NOT allow body to touch a leak in the fluid hose. • NEVER put your hand in front of the gun. Gloves will not provide protection against an injection injury.
<p>0 bar</p>	<ul style="list-style-type: none"> • ALWAYS lock the gun trigger, shut the fluid pump off and release all pressure before servicing, cleaning the tip guard, changing tips, or leaving unattended. Pressure will not be released by turning off the engine. The PRIME/SPRAY valve or pressure bleed valve must be turned to their appropriate positions to relieve system pressure.
	<ul style="list-style-type: none"> • ALWAYS keep tip guard in place while spraying. The tip guard provides some protection but is mainly a warning device. • NEVER use a spray gun without a working trigger lock and trigger guard in place. • ALWAYS remove the spray tip before flushing or cleaning the system.
	<ul style="list-style-type: none"> • The paint hose can develop leaks from wear, kinking and abuse. A leak can inject material into the skin. Inspect the hose before each use.
	<ul style="list-style-type: none"> • All accessories must be rated at or above the maximum operating pressure range of the sprayer. This includes spray tips, guns, extensions, and hose.

	<p>NOTE TO PHYSICIAN: Injection into the skin is a traumatic injury. It is important to treat the injury as soon as possible. DO NOT delay treatment to research toxicity. Toxicity is a concern with some coatings injected directly into the blood stream. Consultation with a plastic surgeon or reconstructive hand surgeon may be advisable.</p>
--	-------------------------------------------------------------------------------------------------------------------------------------------------------------------------------------------------------------------------------------------------------------------------------------------------------------------------------------------------------------------------

	<p>HAZARD: EXPLOSION OR FIRE Solvent and paint fumes can explode or ignite. Severe injury and/or property damage can occur.</p>
	<p>PREVENTION:</p>
	<ul style="list-style-type: none"> • Provide extensive exhaust and fresh air introduction to keep the air within the spray area free from accumulation of flammable vapors.
	<ul style="list-style-type: none"> • Avoid all ignition sources such as static electricity sparks, electrical appliances, flames, pilot lights, hot objects, and sparks from connecting and disconnecting power cords or working light switches. • Plastic can cause static sparks. Never hang plastic to enclose spray area. Do not use plastic drop cloths when spraying flammable materials. • Always flush unit into separate metal container, at low pump pressure, with spray tip removed. Hold gun firmly against side of container to ground container and prevent static sparks.
	<ul style="list-style-type: none"> • Do not smoke in spray area. • Fire extinguisher must be present and in good working order.
	<ul style="list-style-type: none"> • Place sprayer at least 6.1 m (20 feet) from the spray object in a well ventilated area (add more hose if necessary). Flammable vapors are often heavier than air. Floor area must be extremely well ventilated. The pump contains arcing parts that emit sparks and can ignite vapors.
<p>PE</p>	<ul style="list-style-type: none"> • The equipment and objects in and around the spray area must be properly grounded to prevent static sparks. • Use only conductive or earthed high pressure fluid hose. Gun must be earthed through hose connections. • Power cord must be connected to a grounded circuit (electric units only). • The unit must be connected to an earthed object. Use the green earthing wire to connect the unit to a water pipe, steel beam, or other electrically earthed surface.
	<ul style="list-style-type: none"> • Follow material and solvent manufacturer's warnings and instructions. Be familiar with the coating material's MSDS sheet and technical information to ensure safe use.
	<ul style="list-style-type: none"> • Do not use materials with a flashpoint below 21° C (70° F). Flashpoint is the temperature at which a fluid can produce enough vapors to ignite. • Use lowest possible pressure to flush equipment.

	<p>HAZARD: EXPLOSION HAZARD DUE TO INCOMPATIBLE MATERIALS Will cause severe injury or property damage.</p>
	<p>PREVENTION:</p> <ul style="list-style-type: none"> Do not use materials containing bleach or chlorine. Do not use halogenated hydrocarbon solvents such as methylene chloride and 1,1,1 - trichloroethane. They are not compatible with aluminum and may cause an explosion. If you are unsure of a material's compatibility with aluminum, contact your coating's supplier.

	<p>HAZARD: GENERAL This product can cause severe injury or property damage.</p>
	<p>PREVENTION:</p> <ul style="list-style-type: none"> Read all instructions and safety precautions before operating equipment. Follow all appropriate local, state, and national codes governing ventilation, fire prevention, and operation. Pulling the trigger causes a recoil force to the hand that is holding the spray gun. The recoil force of the spray gun is particularly powerful when the tip has been removed and a high pressure has been set on the airless pump. When cleaning without a spray tip, set the pressure control knob to the lowest pressure. Use only manufacturer authorized parts. User assumes all risks and liabilities when using parts that do not meet the minimum specifications and safety devices of the pump manufacturer.
	<ul style="list-style-type: none"> Before each use, check all hoses for cuts, leaks, abrasion or bulging of cover. Check for damage or movement of couplings. Immediately replace the hose if any of these conditions exist. Never repair a paint hose. Replace it with another earthed high-pressure hose.
	<ul style="list-style-type: none"> Make sure power cord, air hose and spray hoses are routed in such a manner to minimize slip, trip and fall hazard. Clean up all material and solvent spills immediately to prevent slip hazard.
	<ul style="list-style-type: none"> ALWAYS follow the material manufacturer's instructions for safe handling of paint and solvents.
	<ul style="list-style-type: none"> Do not use this unit in workshops that are covered under the explosion prevention regulations.
	<ul style="list-style-type: none"> Always unplug cord from outlet before working on equipment (electric units only). Always keep the power cord plug in sight during usage to prevent any accidental shutdown or startup.
	<ul style="list-style-type: none"> Wear ear protection. This unit can produce noise levels above 85 dB(A).
	<ul style="list-style-type: none"> Device weighs in excess of 36 kg. Three-person lift is required.
	<ul style="list-style-type: none"> Never leave this equipment unattended. Keep away from children or anyone not familiar with the operation of airless equipment. Do not move unit while unit is running. Do not spray on windy days.

	<p>HAZARD: HAZARDOUS VAPORS Paints, solvents, insecticides, and other materials can be harmful if inhaled or come in contact with body. Vapors can cause severe nausea, fainting, or poisoning.</p>
 	<p>PREVENTION:</p> <ul style="list-style-type: none"> Use a respirator or mask if vapors can be inhaled. Read all instructions supplied with the mask to be sure it will provide the necessary protection. Wear protective eyewear. Wear protective clothing as required by coating manufacturer.

1.1 Earthing Instructions



Electric models must be earthed. In the event of an electrical short circuit, earthing reduces the risk of electric shock by providing an escape wire for the electric current. This product is equipped with a cord having an earthing wire with an appropriate earthing plug. The plug must be plugged into an outlet that is properly installed and earthed in accordance with all local codes and ordinances.



DANGER — Improper installation of the earthing plug can result in a risk of electric shock. If repair or replacement of the cord or plug is necessary, do not connect the green earthing wire to either blade terminal. The wire with insulation having a green outer surface with or without yellow stripes is the earthing wire and must be connected to the earthing pin.

Check with a qualified electrician or serviceman if the earthing instructions are not completely understood, or if you are in doubt as to whether the product is properly earthed. Do not modify the plug provided. If the plug will not fit the outlet, have the proper outlet installed by a qualified electrician.



Caution – The power cord for this equipment acts as an emergency stop/emergency switching off device. The power cord must be placed near an easily accessible, unobstructed socket-outlet.

Work or repairs at the electrical equipment:

These may only be carried out by a skilled electrician. No liability is assumed for incorrect installation.

A list of the materials used in the construction of the equipment will be made available on request to validate compatibility with the coating materials to be used.

Operating Temperature

This equipment will operate correctly in its intended ambient, at a minimum between +10°C and +40°C.

Relative Humidity

The equipment will operate correctly within an environment at 50% RH, +40°C. Higher RH may be allowed at lower temperatures.

Measures shall be taken by the Purchaser to avoid the harmful effects of occasional condensation.

Altitude

This equipment will operate correctly up to 2100 m above mean sea level.

Transportation and Storage

This equipment will withstand, or has been protected against, transportation and storage temperatures of -25°C to +55°C and for short periods up to +70°C.

It has been packaged to prevent damage from the effects of normal humidity, vibration and shock.

2. General view of application

2.1 Application

All painting jobs in the workshop and on the building site, small dispersion work with the spray gun or internally fed Airless roller.

Examples of objects of spraying

Doors, door frames, balustrades, furniture, wooden cladding, fences radiators (heating) and steel parts, internal ceilings and walls.

2.2 Coating materials

Processible coating materials



Pay attention to the Airless quality of the coating materials to be processed.

Dilutable lacquers and paints or those containing solvents, two-component coating materials, dispersions, latex paints.

No other materials should be used for spraying without Titan's approval.

Filtering

Despite suction filter and insertion filter in the spray gun, filtering of the coating material is generally advisable.

Stir coating material before commencement of work.



Attention: Make sure, when stirring up with motor-driven agitators that no air bubbles are stirred in. Air bubbles disturb when spraying and can, in fact, lead to interruption of operation.

Viscosity

With this unit it is possible to process highly viscous coating materials of up to around 30.000 MPa·s.

If highly viscous coating materials cannot be taken in by suction, they must be diluted in accordance with the manufacturer's instructions.

Two-component coating material

The appropriate processing time must be adhered to exactly. Within this time rinse through and clean the unit meticulously with the appropriate cleaning materials.

Coating materials with sharp-edged additional materials

These have a strong wear and tear effect on valves, high-pressure hose, spray gun and tip. The durability of these parts can be reduced appreciably through this.

3. Description of unit

3.1 Airless process

The main areas of application are thick layers of highly viscous coating material for large areas and a high consumption of material.

A piston pump takes in the coating material by suction and conveys it to the tip. Pressed through the tip at a pressure of up to a maximum of 214 bar (21.4 MPa), the coating material is atomised. This high pressure has the effect of micro fine atomisation of the coating material.

As no air is used in this process, it is described as an AIRLESS process.

This method of spraying has the advantages of finest atomisation, cloudless operation and a smooth, bubble-free surface. As well as these, the advantages of the speed of work and convenience must be mentioned.

3.2 Functioning of the unit

In the following there is a short description of the technical construction for better understanding of the function.

Titan Performance Series units are electrically driven high-pressure spraying units.

A gear unit transfers the driving force to a crankshaft. The crankshaft moves the pistons of the material feed pump up and down.

The inlet valve is opened automatically by the upwards movement of the piston. The outlet valve is opened when the piston moves downward.

The coating material flows under high pressure through the high-pressure hose to the spray gun. When the coating material exits from the tip it atomizes.

The pressure regulator controls the volume and the operating pressure of the coating material.

3.3 Legend for explanatory diagram Performance Series 1150e

- | | |
|---------------------------------------------------------------------------------|-------------------------------------------------|
| 1 Spray gun | 8 Suction hose |
| 2 High-pressure hose | 9 Relief valve |
| 3 Pressure control knob / ON OFF switch | Lever position vertical – PRIME (↻ circulation) |
| 4 Pressure gauge | Lever position horizontal – SPRAY (→) |
| 5 Oil cup for Piston Lube (Piston Lube prevents increased wear of the packings) | 10 Cart assembly |
| 6 Pail bracket | 11 Circuit breaker |
| 7 Return hose | 12 Power cord |

3.4 Explanatory diagram Performance Series 1150e

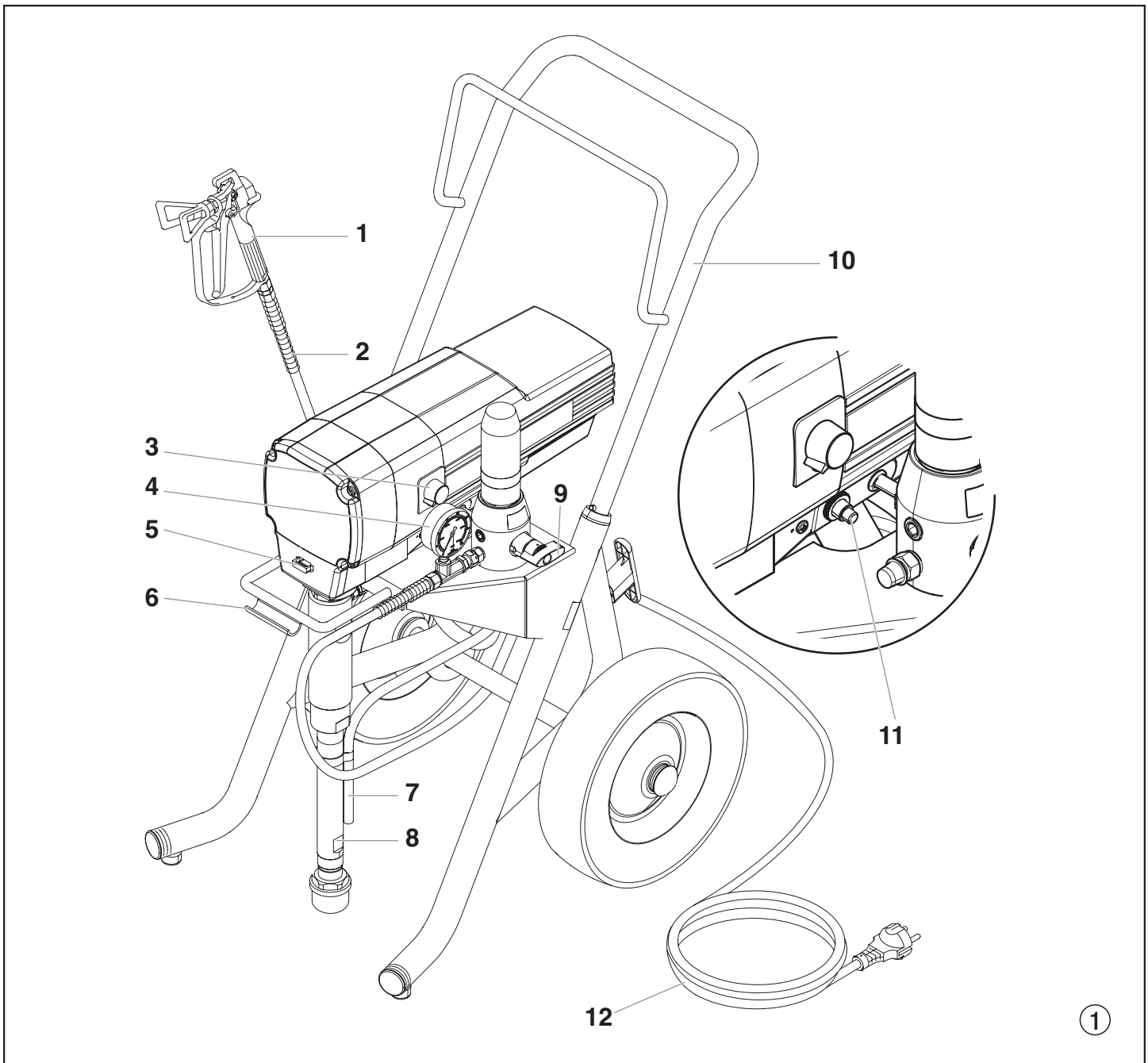

3.5 Technical data

Voltage:	110 Volt AC, 50/60 Hz
Max. current consumption:	13.7 A @ 110VAC
Power cord:	3 x 1.5 mm ² – 6 m
Acceptance capacity:	1300 Watt
Max. operating pressure:	214 bar (21,4 MPa)
Volume flow at 12 MPa (120 bar) with water:	2.88 l/min
Max tip size:	0.033 inch – 0.84 mm
Max. temperature of the coating material:	43°C
Max viscosity:	30.000 mPa·s
Weight:	47,6 kg
Special high-pressure hose:	6,35 mm, 15 m-18 NPSM
Dimensions (L X W X H):	605 x 540 x 745 mm
Vibration:	Spray gun does not exceed 2.5m/s ²
Max sound pressure level:	80 dB (A) *

* Place of measuring: 1 m in distance from the unit and 1.6 m above the floor, 12 MPa (120 bar) operating pressure, reverberant floor.

3.6 Transportation

Pushing or pulling the unit

Pull out the handle (Fig. 2, Item 1) until it will come no further. Insert the handle – push the buttons (2) on the spars, and then push in the handle.

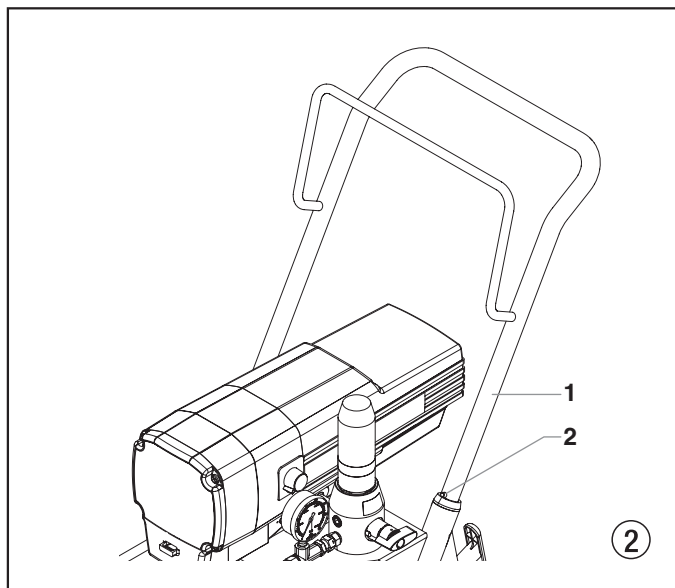

3.7 Transportation in vehicle

Secure the unit with a suitable fastening.

4. Starting operation

4.1 High-pressure hose, spray gun and separating oil

1. Screw the pressure gauge (1) to the coating material outlet (Fig. 3, Item 2).
2. Screw the high-pressure hose (3) to the coating material outlet on the pressure gauge (Fig. 3, Item 4).
3. Screw the spray gun (5) with the selected tip onto the high-pressure hose.
4. Tighten the union nuts at the high-pressure hoses firmly so that coating material does not leak.

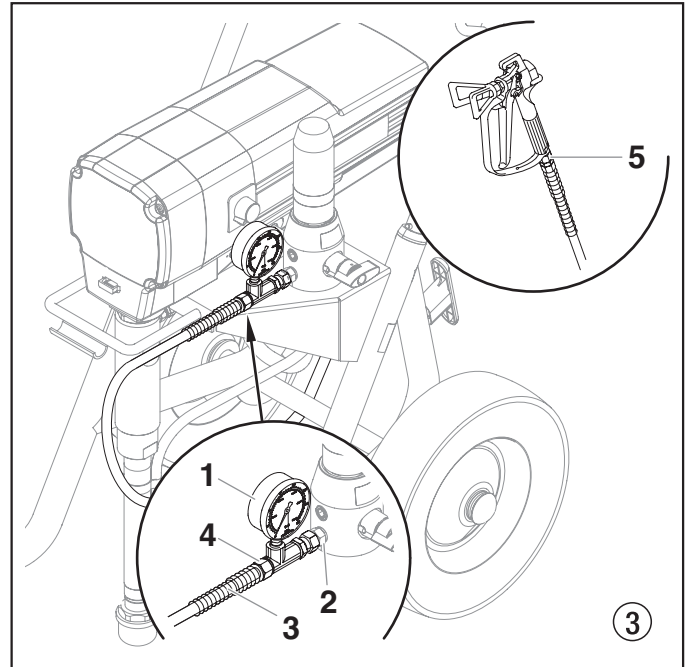

5. Fill the oil cup with Piston Lube (Fig. 4). Do not use too much Piston Lube, i.e. ensure that no Piston Lube drips into the coating material container.



Piston Lube prevents increased wear and tear to the packings.

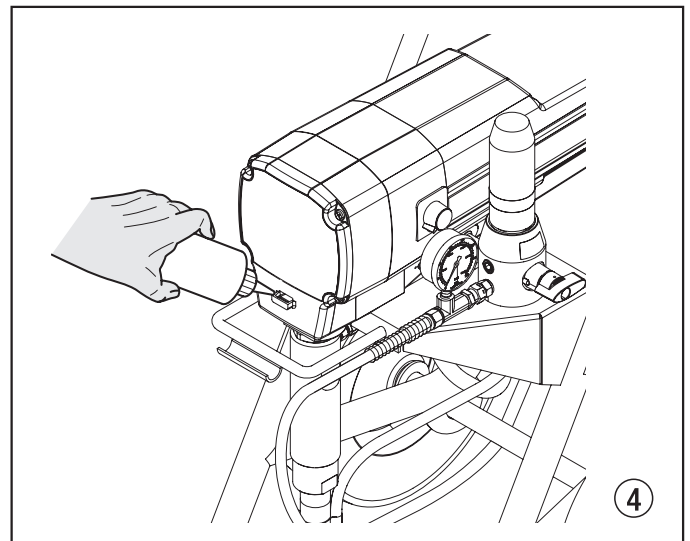

4.2 Pressure control knob settings (Fig. 5)

1. Yellow zone (Minimum Bar - 115 Bar)
2. Green zone (115 - 230 Bar)
3. Black zone (pump turned OFF)
4. Red zone (Pulse Clean)

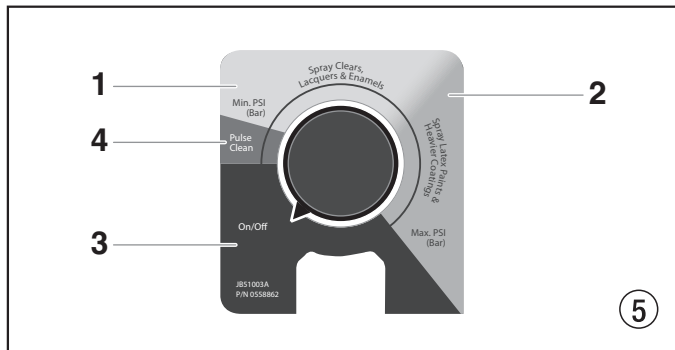

4.3 Connection to the mains network



The unit must be connected to an appropriately-grounded safety outlet.

Before connecting the unit to the mains supply, ensure that the line voltage matches that specified on the unit's rating plate.

4.4 Cleaning preserving agent when starting-up of operation initially

1. Immerse the suction tube (Fig. 6, Item 2) and return hose (1) into a container with a suitable cleaning agent.
2. Open the relief valve (3), valve position PRIME (circulation).
3. Switch the unit (4) ON.
4. Turn the pressure control knob (5) to minimum pressure in the yellow zone.
5. Wait until the cleaning agent exudes from the return hose.
6. Close the relief valve, valve position SPRAY (spray).
7. Pull the trigger of the spray gun.
8. Spray the cleaning agent from the unit into an open collecting container.

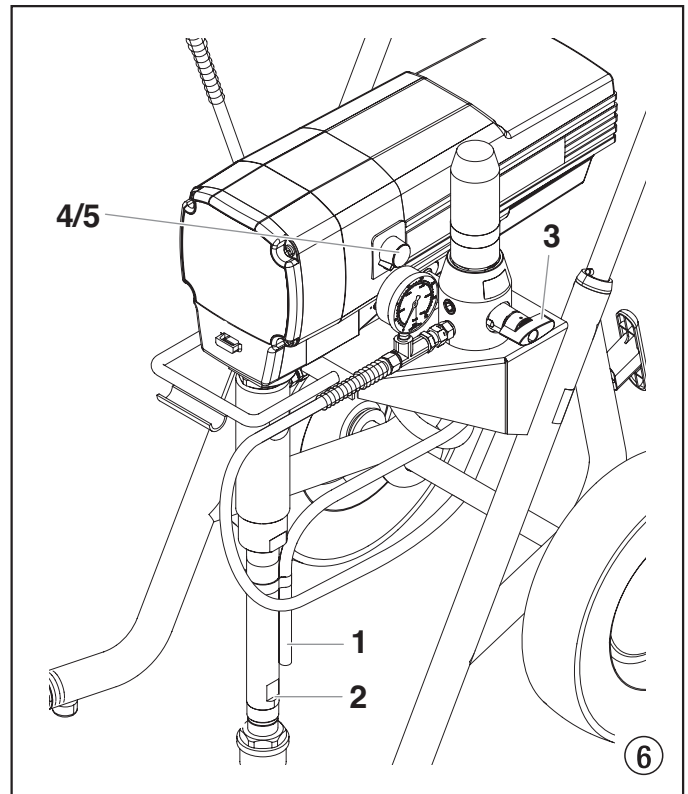

4.5 Taking the unit into operation with coating material

1. Immerse the suction tube (Fig. 6, Item 2) and return hose (1) into the coating material container.
2. Open the relief valve (3), valve position PRIME (circulation).
3. Switch the unit (4) ON.
4. Turn the pressure control knob (5) to minimum pressure in the yellow zone.
5. Wait until the coating material exudes from the return hose.
6. Close the relief valve, valve position SPRAY (spray).
7. Trigger the spray gun several times and spray into a collecting container until the coating material exits the spray gun without interruption.
8. Increase the pressure by slowly turning up the pressure control knob.
Check the spray pattern and increase the pressure until the atomization is correct.
Always turn the pressure control knob to the lowest setting with good atomization.
9. The unit is ready to spray.

5. Spraying technique



Injection hazard. Do not spray without the tip guard in place. NEVER trigger the gun unless the tip is completely turned to either the spray or the unclog position. ALWAYS engage the gun trigger lock before removing, replacing or cleaning tip.

The key to a good paint job is an even coating over the entire surface. Keep your arm moving at a constant speed and keep the spray gun at a constant distance from the surface. The best spraying distance is 25 to 30 cm between the spray tip and the surface.

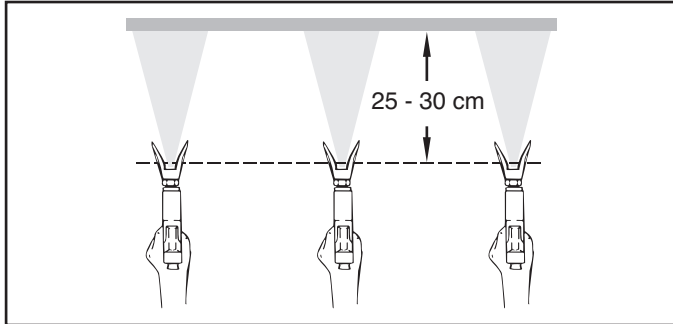

Keep the spray gun at right angles to the surface. This means moving your entire arm back and forth rather than just flexing your wrist.

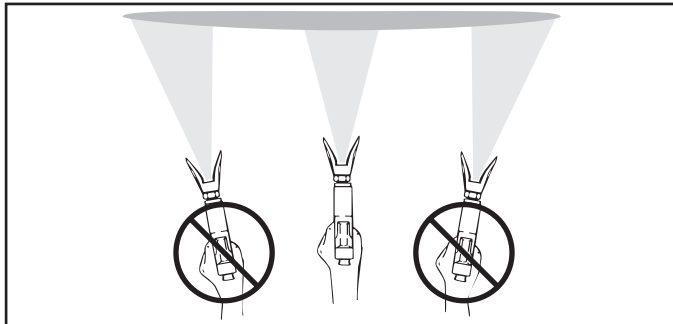

Keep the spray gun perpendicular to the surface, otherwise one end of the pattern will be thicker than the other.

Trigger gun after starting the stroke. Release the trigger before ending the stroke. The spray gun should be moving when the trigger is pulled and released. Overlap each stroke by about 30%. This will ensure an even coating.

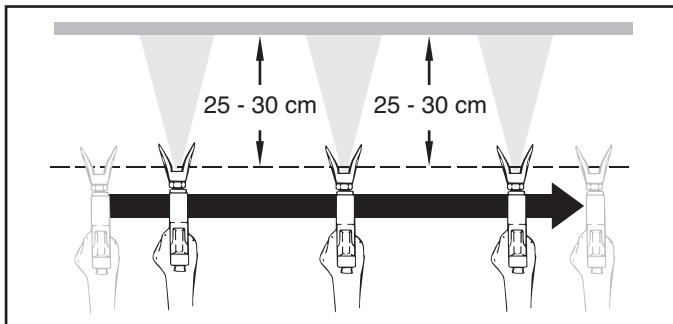

If very sharp edges result or if there are streaks in the spray jet – increase the operating pressure or dilute the coating material.

6. Handling the high-pressure hose

Avoid sharp bending or kinking of the high-pressure hose. The smallest bending radius amounts to about 20 cm.

Do not drive over the high-pressure hose. Protect against sharp objects and edges.



Danger of injury through leaking high-pressure hose. Replace any damaged high-pressure hose immediately.

Never repair defective high-pressure hoses yourself!

6.1 High-pressure hose

The unit is equipped with a high-pressure hose specially suited for piston pumps.



Only use Titan original-high-pressure hoses in order to ensure functionality, safety and durability.

7. Interruption of work

1. Open the relief valve, valve position PRIME (↻ circulation).
2. Turn the pressure control knob to OFF in the black zone.
3. Pull the trigger of the spray gun in order to release the pressure from the high-pressure hose and spray gun.
4. Secure the spray gun, refer to the operating manual of the spray gun.
5. If a standard tip is to be cleaned, see Page 21, Section 13.2.
If a non-standard tip is installed, proceed according to the relevant operating manual.
6. Leave the suction tube and return hose immersed in the coating material or swivel or immerse it into a corresponding cleaning agent.



Attention

If fast-drying or two-component coating material is used, ensure that the unit is rinsed with a suitable cleaning agent within the processing time.

8. Cleaning the unit (shutting down)

A clean state is the best method of ensuring operation without problems. After you have finished spraying, clean the unit. Under no circumstances may any remaining coating material dry and harden in the unit.

The cleaning agent used for cleaning (only with an ignition point above 21 °C) must be suitable for the coating material used.

- **Secure the spray gun**, refer to the operating manual of the spray gun.

Clean and remove tip.

For a standard tip, refer to Page 21, Section 13.2.

If a non-standard tip is installed, proceed according to the relevant operating manual.

1. Remove suction hose from the coating material.
2. Close the relief valve, valve position SPRAY (☞ spray).
3. Switch the unit ON.
4. Pull the trigger of the spray gun in order to pump the remaining coating material from the suction hose, high-pressure hose and the spray gun into an open container.



Attention

The container must be earthed in case of coating materials which contain solvents.



Caution! Do not pump or spray into a container with a small opening (bunghole)! Refer to the safety regulations.

5. Immerse suction hose with return hose into a container with a suitable cleaning agent.
6. Turn the pressure control knob to Pulse Clean in the red zone.
7. Open the relief valve, valve position PRIME (↻ circulation).
8. Pump a suitable cleaning agent in the circuit for a few minutes.
9. Close the relief valve, valve position SPRAY (☞ spray).
10. Pull the trigger of the spray gun.
11. Pump the remaining cleaning agent into an open container until the unit is empty.
12. Switch the unit OFF.

8.1 Cleaning unit from outside



First of all pull out mains plug from socket.



Attention

Danger of short circuit through penetrating water!

Never spray down the unit with high-pressure or high-pressure steam cleaners.

Wipe down unit externally with a cloth which has been immersed in a suitable cleaning agent.

8.2 Cleaning the high-pressure filter

Clean the filter cartridge regularly.

A soiled or clogged high-pressure filter can cause a poor spray pattern or a clogged tip.

1. Turn the pressure control knob to OFF in the black zone.



Unplug the power plug from the outlet.

2. Open the relief valve, valve position PRIME (↻ circulation).
3. Unscrew the filter housing (Fig. 7, Item 1) with a strap wrench.
4. Pull the filter cartridge (2) from the bearing spring (3).
5. Clean all the parts with the corresponding cleaning agent. If necessary, replace the filter cartridge.
6. Check the O-ring (4), replace it if necessary.
7. Place the bearing ring (5) against the bearing spring (3). Slide the filter cartridge (2) over the bearing spring.
8. Screw in filter housing (1) and tighten it as far as possible with the strap wrench.

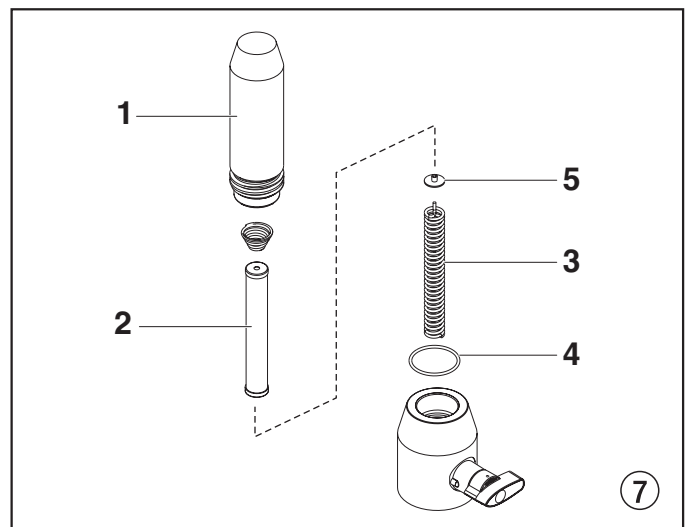

8.3 Cleaning the Airless spray gun

1. Rinse Airless spray gun with an appropriate cleaning agent.
2. Clean tip thoroughly with appropriate cleaning agent so that no coating material residue remains.
3. Thoroughly clean the outside of the Airless spray gun.

Intake filter in Airless spray gun

1. Pull the bottom of the trigger guard forward (1) so that it comes loose from the handle assembly (5).
2. Loosen and remove the handle assembly (5) from the gun head (2).
3. Turning clockwise, unscrew the filter (4) from the gun body (2).



Left-handed threads require turning the filter clockwise to remove.

4. Turning counterclockwise, screw the new or cleaned filter into the gun body.
5. Make sure all the parts are clean and the handle seal (3) is in position inside the gun head.
6. Thread the handle assembly (5) into the gun head (2) until secure.
7. Snap the trigger guard (1) back onto the handle assembly (5).

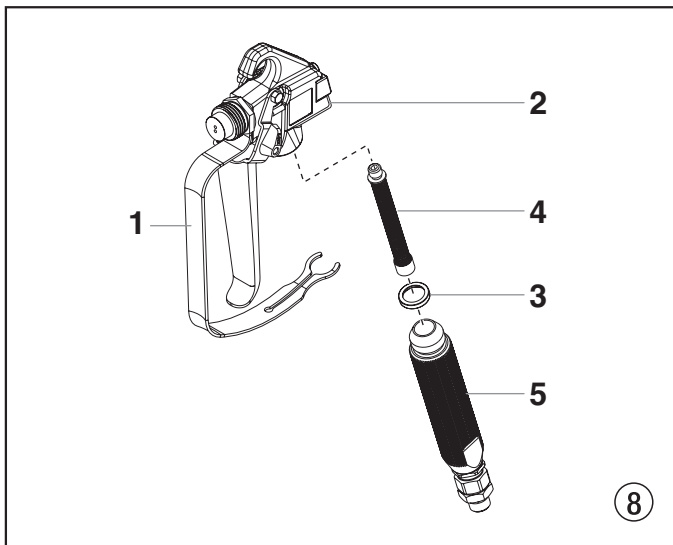

9. Remedy in case of faults

Type of malfunction	Possible cause	Measures for eliminating the malfunction
A. Unit does not start	<ol style="list-style-type: none"> No voltage applied. Pressure setting too low. ON/OFF switch defective. 	<ol style="list-style-type: none"> Check voltage supply. Turn up pressure control knob. Replace.
B. Unit does not draw in material	<ol style="list-style-type: none"> Relief valve is set to SPRAY (☞ spray). Filter projects over the fluid level and sucks air. Filter clogged. Suction hose/suction tube is loose, i.e. the unit is sucking in outside air. 	<ol style="list-style-type: none"> Set relief valve to PRIME (↻ circulation). Refill the coating material. Clean or replace the filter. Clean connecting points. Tighten suction tube.
C. Unit draws in material, but the pressure does not build up	<ol style="list-style-type: none"> Tip heavily worn. Tip too large. Pressure setting too low. Filter clogged. Coating material flows through the return hose when the relief valve is in the SPRAY (☞ spray) position. Packings sticky or worn. Valve balls worn. Valve seats worn. 	<ol style="list-style-type: none"> Replace Replace tip. Turn pressure control knob clockwise to increase. Clean or replace the filter. Remove and clean or replace relief valve. Remove and clean or replace packings. Remove and replace valve balls. Remove and replace valve seats.
D. Coating material exits at the top of the fluid section	<ol style="list-style-type: none"> Upper packing is worn. Piston is worn. 	<ol style="list-style-type: none"> Remove and replace packing. Remove and replace piston.
E. Increased pulsation at the spray gun	<ol style="list-style-type: none"> Incorrect high-pressure hose type. Tip worn or too large. Pressure too high. 	<ol style="list-style-type: none"> Only use Titan original-high-pressure hoses in order to ensure functionality, safety and durability. Replace tip. Turn pressure control knob to a lower number.
F. Poor spray pattern	<ol style="list-style-type: none"> Tip is too large for the coating material which is to be sprayed. Pressure setting incorrect. Volume too low. Coating material viscosity too high. 	<ol style="list-style-type: none"> Replace tip. Turn pressure control knob until a satisfactory spraying pattern is achieved. Clean or replace all filters. Thin out according to the manufacturer's instructions.
G. Unit loses power	<ol style="list-style-type: none"> Pressure setting too low. 	<ol style="list-style-type: none"> Turn pressure control knob clockwise to increase.

10. Servicing

10.1 General servicing

Servicing of the unit should be carried out once annually by the Titan service.

1. Check high-pressure hoses, device connecting line and plug for damage.
2. Check the inlet valve, outlet valve and filter for wear.

10.2 High-pressure hose

Inspect the high-pressure hose visually for any notches or bulges, in particular at the transition in the fittings. It must be possible to turn the union nuts freely.

11. Repairs at the unit



Switch the unit OFF.
Before all repair work: Unplug the power plug from the outlet.

11.1 Relief valve

1. Use a drift punch of 2 mm to remove the grooved pin (Fig. 9, Item 1) from the relief valve handle (2).
2. Remove the relief valve handle (2) and cam base (3).
3. Using a wrench, remove the valve housing (4).
4. Ensure that the seal (5) is seated correctly, then screw the new valve housing (4) completely into the filter block (6). Tighten securely with a wrench.
5. Align the cam base (3) with the hole in the filter block (6). Lubricate the cam base with grease and slide on the cam base.
6. Bring the hole in the valve shaft (7) and in the relief valve handle (2) into alignment.
7. Insert the grooved pin (1) to secure the relief valve handle in position.

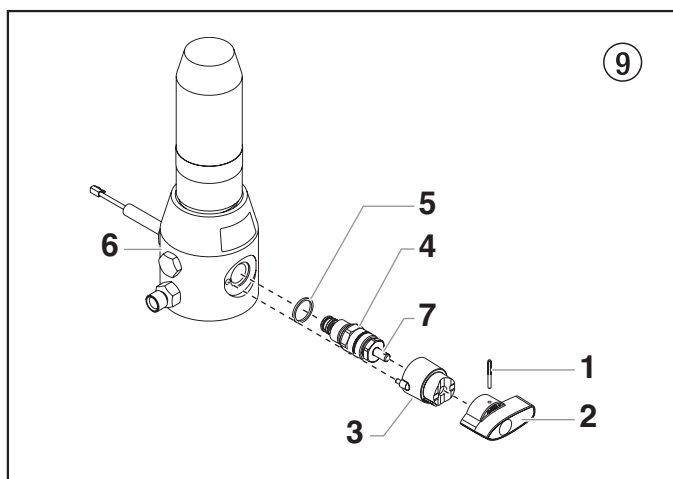

11.2 Inlet and outlet valve

1. Remove the four screws in the front cover and then remove the front cover.
2. Switch the unit ON and OFF so that the retaining ring (Fig. 10, Item 1) on the connecting rod is visible below the guide (2).



Danger of crushing - do not reach with the fingers or tool between the moving parts.

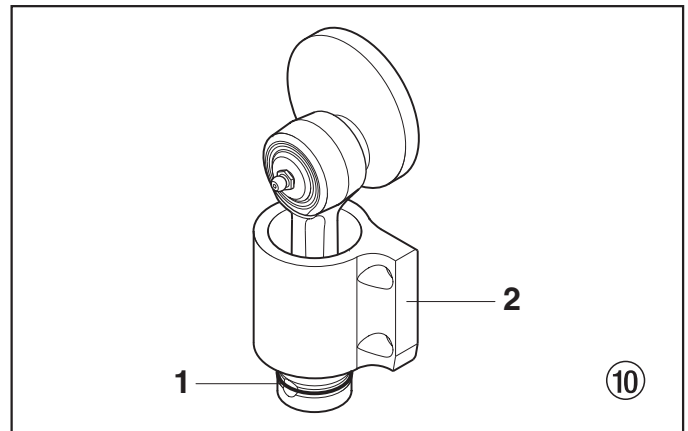

3. Unplug the power plug from the outlet.
4. Pull off clamp on suction tube and remove return hose.
5. Unscrew the connection hose (Fig. 11, Item 1) to the high-pressure filter.
6. Swivel the unit 90° to the rear in order to work more easily on the material feed pump.
7. Slide the retaining ring (2) up on the slider assembly (4) to expose the connecting pin (3).
8. Push the connecting pin (3) forward through the slider assembly (4) and piston (5). The connecting pin will fall into a recessed area of the gear box housing where it can be retrieved.
9. Using a wrench, turn the jam nut (6) counterclockwise to loosen it from the gear box housing.

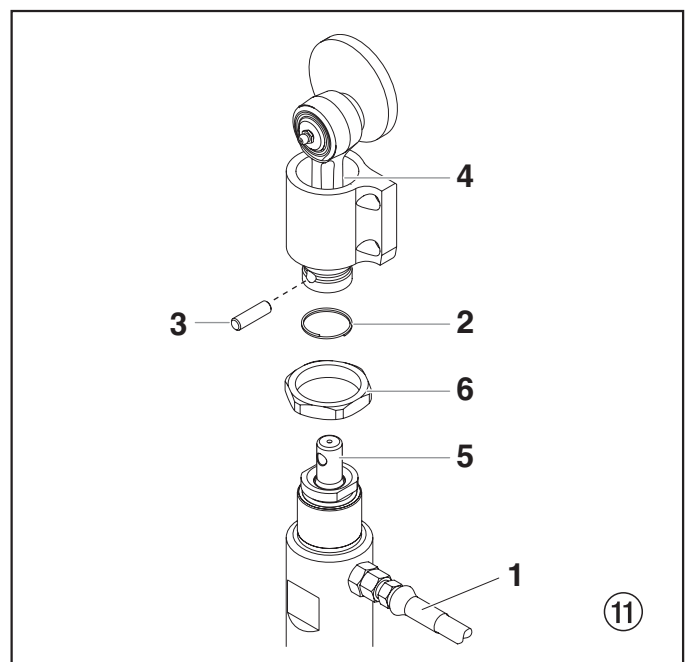

10. Turn the fluid section counterclockwise to remove it from the gear box housing.
11. Place the fluid section cylinder upright in a vise by clamping on the wrench flats (Fig. 12, Item 1).



Do not over-tighten the vise. Damage to the cylinder may occur.

12. Loosen and remove the inlet valve housing (2) from the cylinder.
13. Remove bearing ring (3), O-ring (4), O-ring (5), inlet valve seat (6), inlet valve ball (7) and upper ball guide (8).
14. Clean all the parts with the corresponding cleaning agent. Check the inlet valve housing (2), inlet valve seat (6) and inlet valve ball (7) for wear and replace the parts if necessary. If the worn inlet valve seat (6) is unused on one side, install it the other way around.

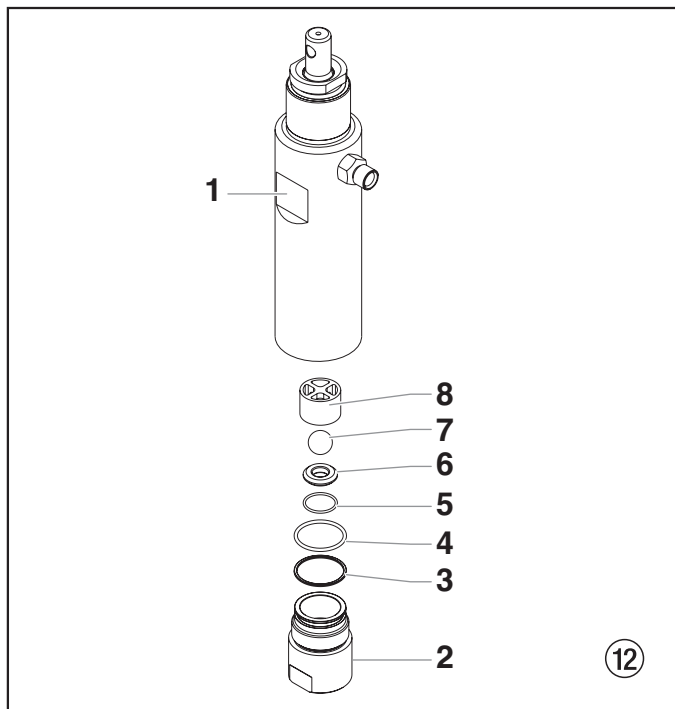

15. Using a wrench, remove the upper seal retainer (Fig. 13, Item 1).
16. Slide the piston rod (2) out through the bottom of the cylinder.
17. Inspect the piston rod (2) for wear and replace if necessary.
20. Remove the cylinder from the vise.
21. Insert the connecting pin (3) through the hole at the top of the piston rod (2) and clamp each end of the connecting pin in the vise. This will hold the piston rod in position for disassembly.



Do not clamp the piston rod directly in the vise. Damage to the piston rod will occur.

19. Using a 3/8" hex wrench, loosen and remove the outlet valve housing (4) from the piston rod (2).
20. Remove the upper seal (5), upper ball guide (6), outlet valve ball (7), washer (8) and outlet valve seat (9).
21. Clean out any debris and examine the retainer (1) and outlet valve seat (9). If the seat is damaged, reverse or replace.

22. Reassemble the outlet valve assembly into the piston rod (2) in the reverse order of how it was disassembled.
23. Remove the piston from the vise and remove connecting rod (3).
24. If you plan to replace the fluid section packings, move on to section 11.3. If not, reassemble fluid section in the reverse order of how it was disassembled.

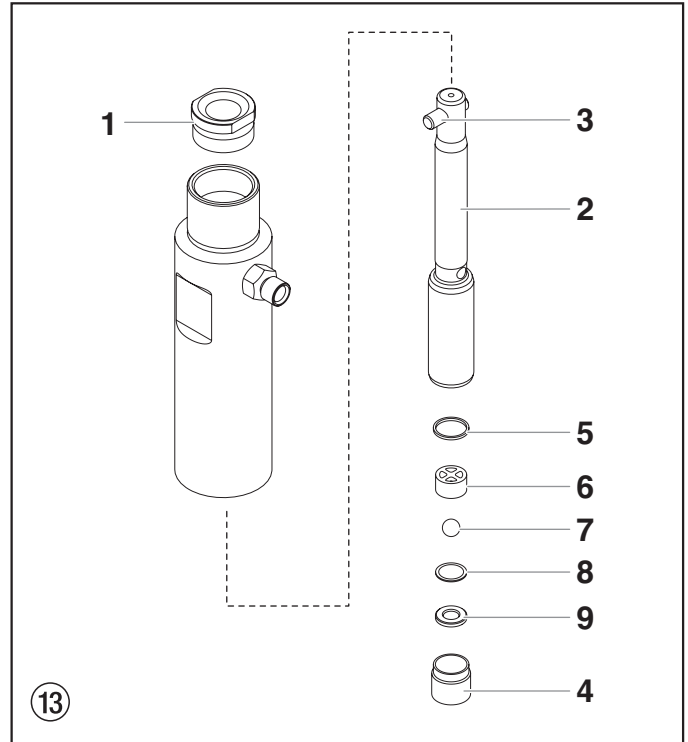

11.3 Packings

1. Remove inlet valve housing and piston in accordance with steps 1-17 in Chapter 11.2, Page 14.
2. It is not necessary to remove the outlet valve.
3. Remove the upper support ring (Fig. 14, Item 6) and upper packing assembly (1) from the top of the cylinder (2).
4. Remove the adapter (3) and lower packing assembly (4) from the bottom of the cylinder.



Be careful not to scratch, score, or otherwise damage the cylinder during removal of the packings.

5. Clean the cylinder (2). Inspect the cylinder for damage and replace if necessary.
6. Place the cylinder (2) upright in a vise by clamping on the wrench flats (5).
7. Locate the new upper and lower packings and remove the pre-form tools. Save the upper packing pre-form tool for use as the piston insertion tool later in this procedure.



Do not remove the pre-form tools from the upper and lower packings until immediately before they are installed into the cylinder.

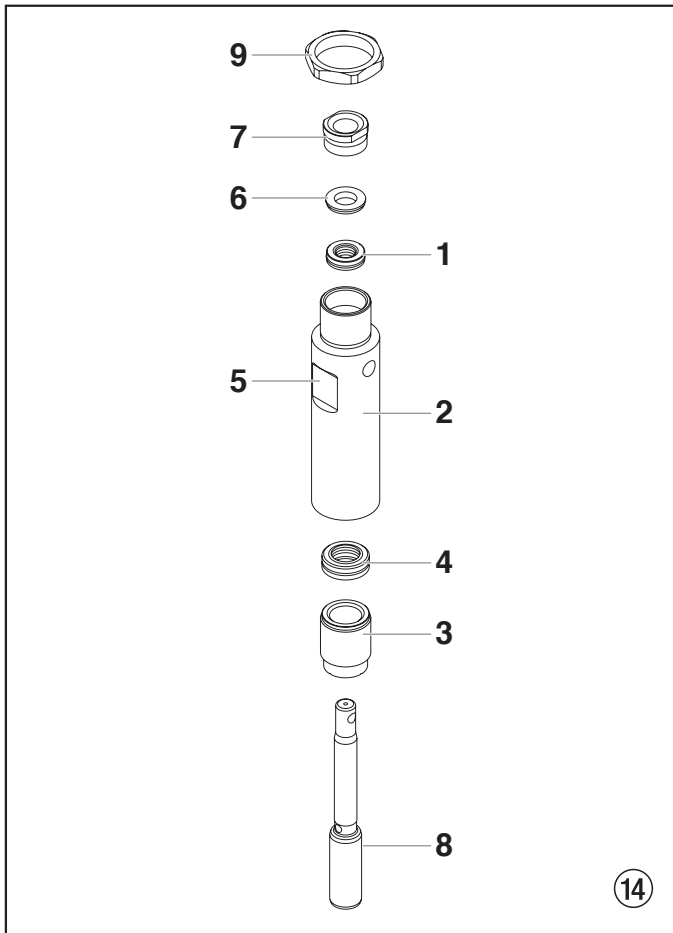

8. Lubricate upper packing (1) and lower packing (4) with machine grease.
9. Insert upper packing (Fig. 15) with O-ring (1) and protruding lip (2) downward.

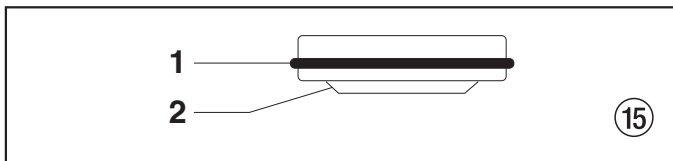

10. Insert upper support ring (6) on top of the upper packing (1)
11. Thread the upper seal retainer (7) into the cylinder (2).
12. Rotate the cylinder in the vise so that the bottom end is facing up.
13. Insert the lower packing partially into the bottom of the cylinder with the large beveled edge facing down. The large beveled edge (Fig. 16. Item 1) will face up when the cylinder is upright.

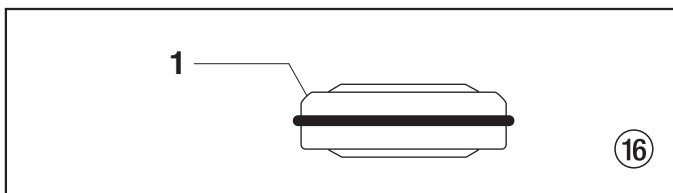

14. Push the lower packing assembly (Fig. 14, Item 4) into position using the lower packing insertion tool (see Fluid Section Assembly parts list for lower packing insertion tool P/N).



Coat the piston insertion tool (i.e. upper packing pre-form tool) and the piston rod with grease before inserting them into the cylinder.

15. Place the piston insertion tool over the top of the piston rod (8).
16. Insert the piston rod (8) into the bottom of the cylinder (2), through the lower packing assembly (4), through the upper packing assembly (1), and out through the upper seal retainer (7).



Make sure the raised lip on the bottom of the lower packing is fully outside the packing around the piston rod after insertion of the piston rod.

17. Remove the piston insertion tool from the top of the piston rod (8).
18. Turn the jam nut (9) counterclockwise until it is flush against the top of the cylinder (2).
19. Lubricate the threads on the cylinder with anti-seize compound. Remove the cylinder from the vise.
20. Thread the cylinder into the gear box housing, turning clockwise. When the connecting pin hole on the piston rod (Fig. 11, item 5) lines up with the hole in the slider assembly (Fig. 11, item 4), insert the connecting pin (Fig. 11, item 3).
21. Slide the retaining ring (Fig. 11, item 2) down over the connecting pin.
22. Continue to turn the cylinder clockwise until the jam nut (Fig. 14, 9) is flush against the gear box housing.



If the nipple on the cylinder does not face the back of the unit, turn the cylinder counterclockwise until the nipple faces the back of the unit. Do not turn the cylinder more than one full turn.

23. Once the nipple is positioned, turn the jam nut clockwise until it contacts the gear box housing.
24. Tighten the jam nut with a wrench to tighten it against the gear box housing.
25. Attach the high-pressure hose to the nipple on the back of the cylinder and tighten with a wrench. Do not kink the hose.
26. Insert the adapter (Fig. 14, item 3) into the bottom of the cylinder.
27. Making sure that the bearing ring (Fig. 12, item 3) and O-rings (Fig. 12, items 4-5) are lubricated and in place, reassemble the inlet valve assembly and thread it into the cylinder. Tighten the inlet valve housing until the o-ring engages, then continue to tighten until snug. Once snug, tighten an additional 1/8–1/4 turn.
28. Thread the siphon tube/suction set into the inlet valve housing and tighten securely. Make sure to wrap the threads on the down tube/siphon hose adapter with Teflon tape before assembly.
29. Replace the return hose into the clamp on the siphon tube.
30. Place the front cover on the gearbox housing and secure in position using the four front cover screws.

11.4 Replacing the motor assembly



Electrostatic discharge (ESD) potential could cause damage to electronic control. Use Titan ESD wrist strap P/N 0507 958 or equivalent when working on electronic control with electronic cover removed.

1. Open the relief valve, valve position PRIME (↻ circulation), switch the unit OFF, and unplug the power cord.
2. Loosen and remove the four motor shroud screws (Fig. 17, item 1). Remove the motor shroud (2).
3. Release the tie wrap on the top of the baffle assembly (3) and slip the baffle assembly down off of the motor (4).
4. Loosen and remove the three electronic cover screws (5). Lift the electronic cover (6) off of the electronic control assembly (7) on the motor.
5. At the electronic control assembly:
 - a. Disconnect the white wire coming from the power cord and the white wire coming from the relay.
 - b. Disconnect the three wires coming from the potentiometer.
6. Loosen and remove the three motor mounting screws (8).
7. Pull the motor (4) out of the gearbox housing (9).
8. With the motor removed, inspect the gears in the gearbox housing for damage or excessive wear. Replace the gears, if necessary.
9. Install the new motor (4) into the gearbox housing (9). Make sure the housing gasket (10) is positioned properly.
10. Secure the motor (4) with the three motor mounting screws (8).
11. Reconnect the wires to the electronic control assembly (refer to the electrical schematic in Section 11.7 of this manual).
12. Position the electronic cover (6) over the electronic control assembly (7). Secure the electronic cover (6) with the three electronic cover screws (5).



Use only Titan electronic cover screws to secure the electronic cover (see Drive Assembly parts list). Use of any other screws may damage the electronic control assembly.

13. Slip the baffle assembly (3) up and around the motor (4). Secure the baffle assembly with the tie wrap.
14. Slide the motor shroud (2) over the motor (4).
15. Secure the motor shroud (2) with the four motor shroud screws (1).

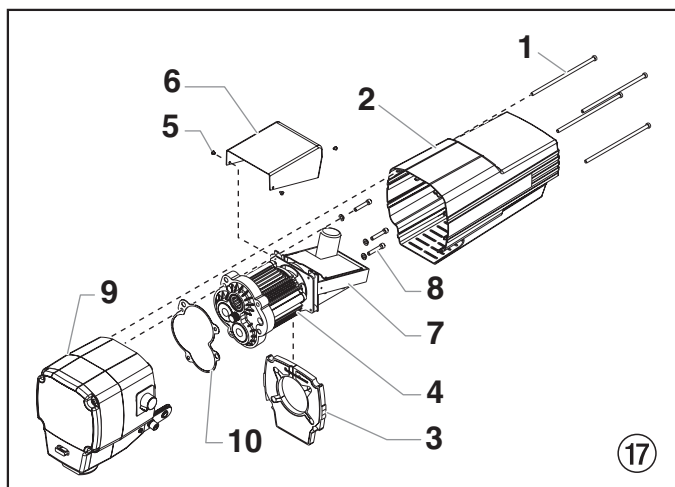

11.5 Replacing the Gears



Electrostatic discharge (ESD) potential could cause damage to electronic control. Use Titan ESD wrist strap P/N 0507 958 or equivalent when working on electronic control with electronic cover removed.

1. Follow steps 1-7 in Section 11.4, page 35.
2. Inspect the armature gear (Fig 18, item 1) on the end of the motor for damage or excessive wear. If this gear is completely worn out, replace the motor.
3. Remove and inspect the 1st stage gear (2) and 2nd stage gear assemblies (3) for damage or excessive wear. Replace, if necessary.
4. Remove and inspect the front gear box assembly (4) for damage or excessive wear. If damaged or worn, replace the front gear box assembly.



Clean and refill the gear box cavity up to the rear face of each gear with grease (P/N 9870 307).

5. Follow steps 9-15 in Section 11.4 to reassemble.

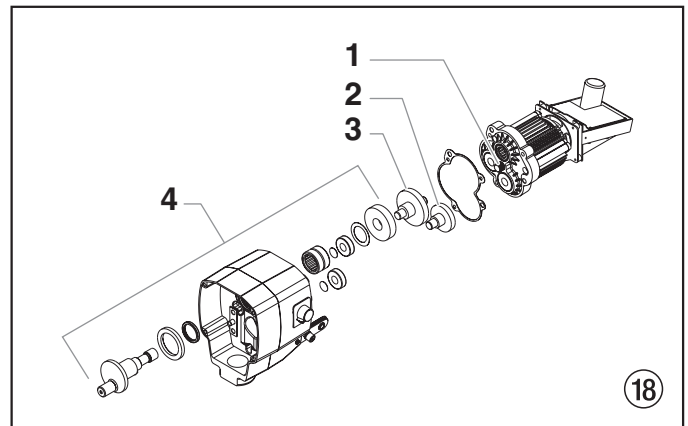

11.6 Replacing the Transducer

1. Open the relief valve, valve position PRIME (↻ circulation), switch the unit OFF, and unplug the power cord.
2. Loosen and remove the four motor shroud screws (Fig. 19, item 1). Remove the motor shroud (2).
3. At the electronic control assembly (3), disconnect the black wire coming from the transducer (4).
4. Pull the grommet (5) out of the mounting plate (6) and slide it up the shaft of the transducer (4) until it is clear of the mounting plate (6).

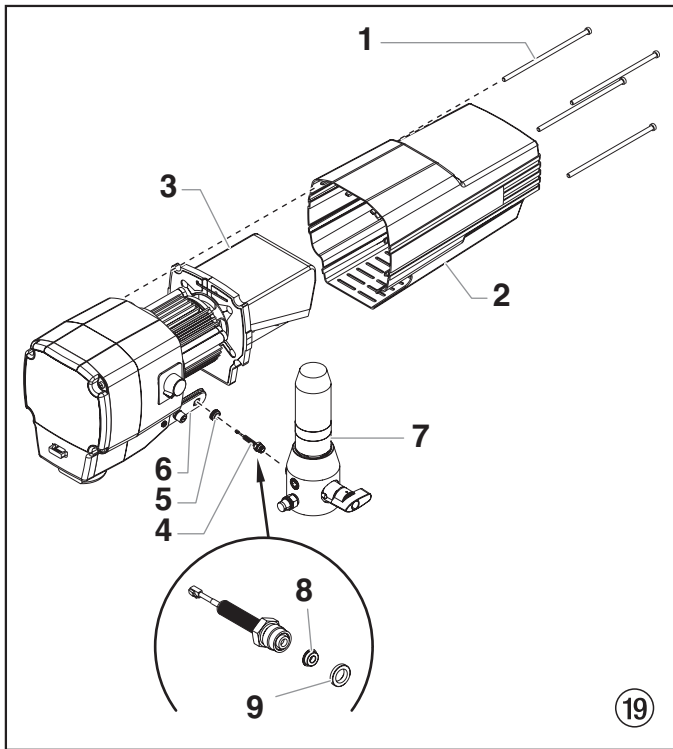

5. Using a wrench, loosen and remove the transducer (4) from the filter housing (7). Carefully thread the transducer wire out through the mounting plate (6). Replace the transducer cap (8) and inner seal (9), if damaged.
6. Slide the grommet (5) off of the old transducer and onto the new transducer.
7. Thread the new transducer wire through the mounting plate (6) and up to the electronic control assembly (3).
8. Thread the new transducer (4) into the filter housing (7) and tighten securely with a wrench.



Make sure the transducer cap and inner seal on the transducer are in place before threading the transducer into the filter housing.

9. Push the grommet (5) into the mounting plate (6).
10. Connect the transducer wire to the electronic control assembly (refer to the electrical schematic in Section 11.7 of this manual).
11. Slide the motor shroud (2) over the motor.
12. Secure the motor shroud (2) with the four motor shroud screws (1).

11.7 Performance Series 1150e connection diagram

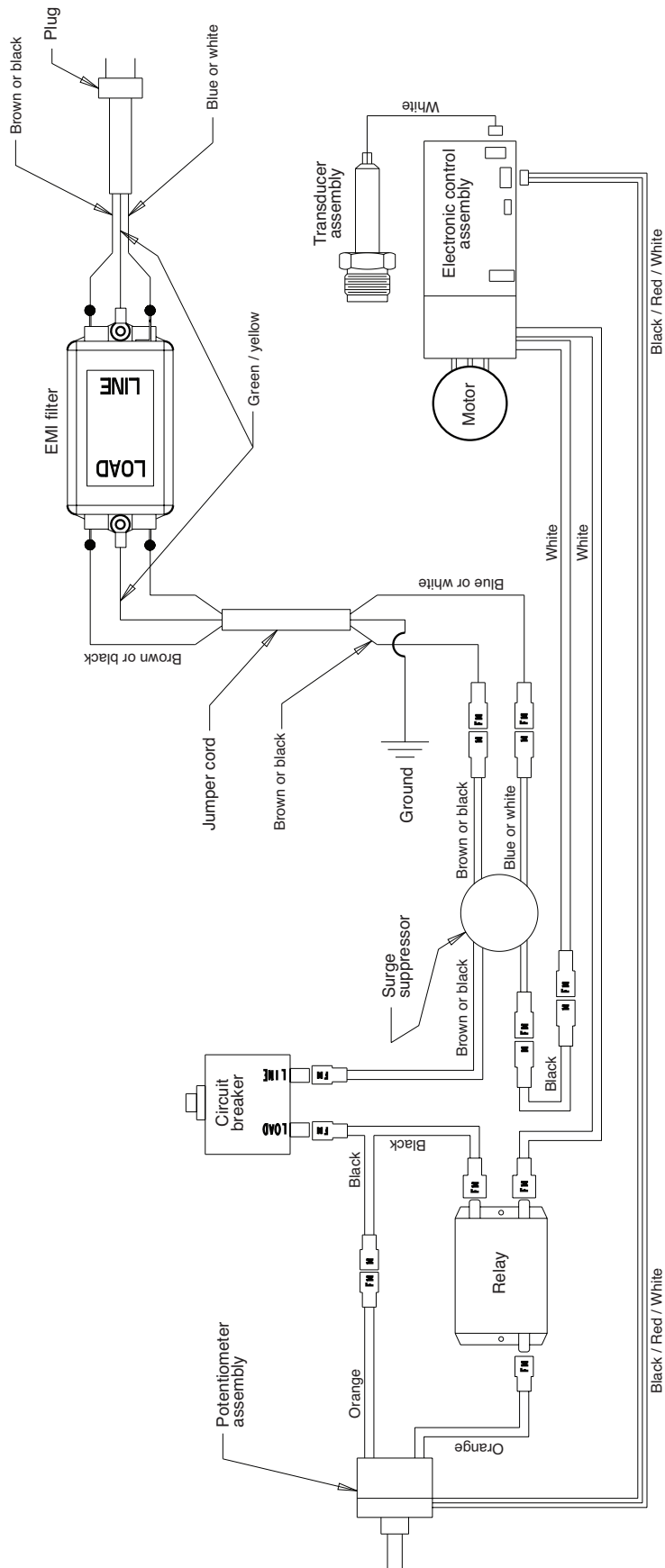

12. Accessories for Performance Series 1150e

Airless Tip Selection

Tips are selected by the orifice size and fan width. The proper selection is determined by the fan width required for a specific job and by the orifice size that will supply the desired amount of fluid and accomplish proper atomization.

For light viscosity fluids, smaller orifice tips generally are desired. For heavier viscosity materials, larger orifice tips are preferred. Please refer to the chart below.



Do not exceed the sprayer's recommended tip size.

The following chart indicates the most common sizes and the appropriate materials to be sprayed.

Tip Size	Spray Material	Filter Type
.011 – .013	Lacquers and stains	100 mesh filter
.015 – .019	Oil and latex	60 mesh filter
.021 – .026	Heavy bodied latex and blockfillers	30 mesh filter

Fan widths measuring 8" to 12" (20 to 30 cm) are preferred because they offer more control while spraying and are less likely to plug.

Liquid Shield Plus

Cleans and protects spray systems against rust, corrosion and premature wear. Now with -25° anti-freeze protection.

Part #	Description
314-483	4 ounce (112 ml) bottle
314-482	1 liter bottle



Piston Lube

Specially formulated to prevent materials from adhering to the piston rod, which becomes abrasive to the upper seals. Piston Lube will break down any material that may accumulate in the oil cup and keep it from drying.

Part #	Description
314-481	4 ounce (112 ml) bottle
314-480	8 ounce (240 ml) bottle



Miscellaneous

Part #	Description
490-012	Hose Coupling, 1/4" x 1/4"
730-397	High Pressure Fl. Gauge
314-171	Lubriplate, 14 ounce individual
314-172	Lubriplate, 6 lb. can

13. Appendix

13.1 Selection of tip

To achieve faultless and rational working, the selection of the tip is of the greatest importance.

In many cases the correct tip can only be determined by means of a spraying test.

Some rules for this:

The spray jet must be even.

If streaks appear in the spray jet the spraying pressure is either too low or the viscosity of the coating material too high.

Remedy: Increase pressure or dilute coating material. Each pump conveys a certain quantity in proportion to the size of the tip:

The following principle is valid:

large tip =	low pressure
small tip =	high pressure

There is a large range of tips with various spraying angles.

13.2 Servicing and cleaning of Airless hard-metal tips

Standard tips

If a different tip type has been fitted, then clean it according to manufacturer's instructions.

The tip has a bore processed with the greatest precision. Careful handling is necessary to achieve long durability. Do not forget the fact that the hard-metal insert is brittle! Never throw the tip or handle with sharp metal objects.

The following points must be observed to keep the tip clean and ready for use:

1. Turn the relief valve handle fully counterclockwise (↺ Circulation).
2. Switch off the gasoline engine.
3. Dismount the tip from the spray gun.
4. Place tip in an appropriate cleaning agent until all coating material residue is dissolved.
5. If there is pressure air, blow out tip.
6. Remove any residue by means of a sharp wooden rod (toothpick).
7. Check the tip with the help of a magnifying glass and, if necessary, repeat points 4 to 6.

Spare parts list

Performance Series 1150e

Main Assembly

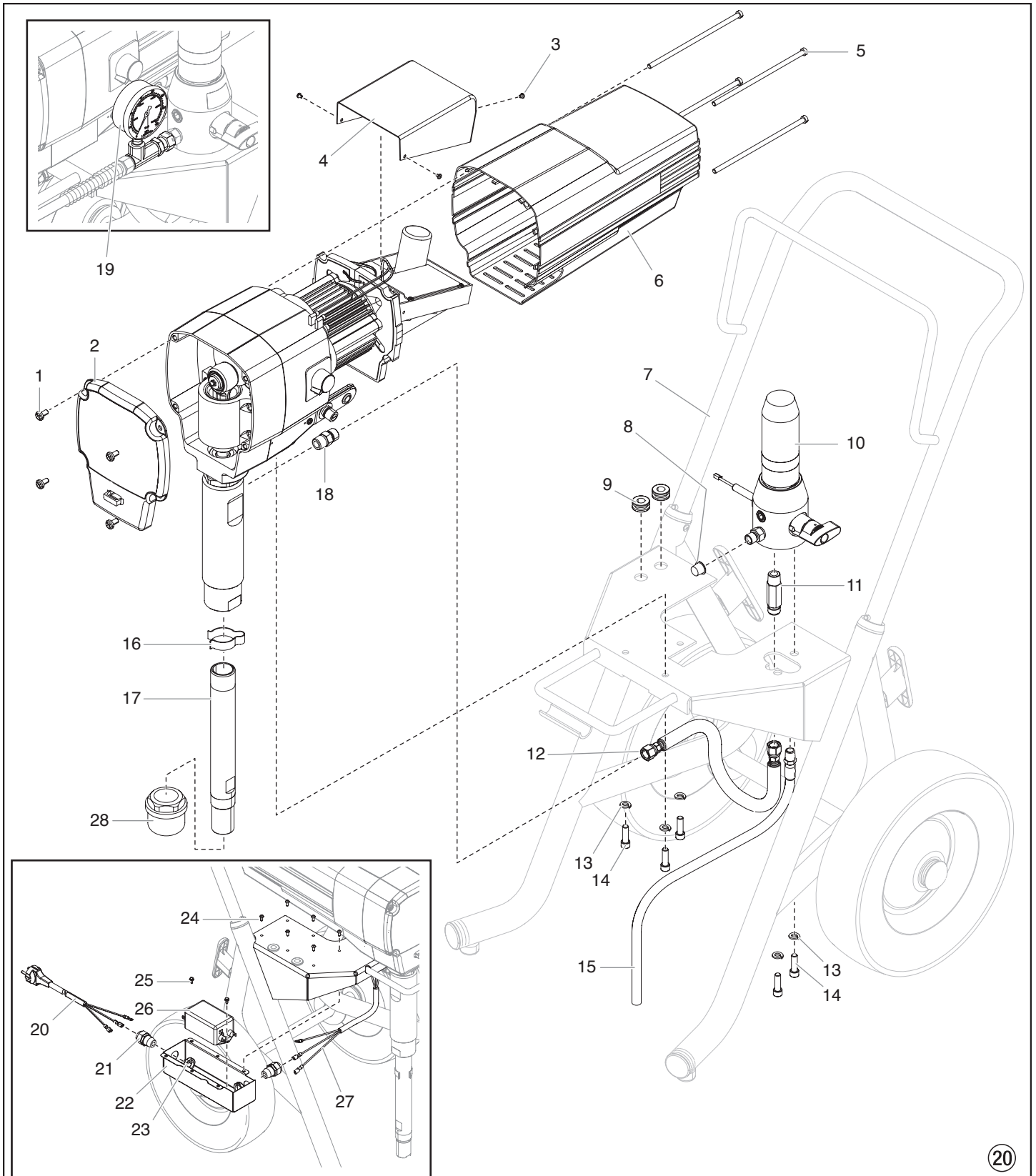

Item	Part No.	Description
1	0507 799	Screw (4)
2	0558 303	Face plate
3	0507 960	Screw (3)
4	0507 959	Electric motor cover
5	0507 771	Screw (4)
6	0558 304	Motor shroud
7	0558 593	Upright cart assembly
8	730-197	Cap
9	800-036	Grommit (2)
10	0558 368A	Filter assembly
11	0507 671	Fitting
12	0507 387	Hose
13	0507 786	Washer (5)
14	9805 311	Screw (5)
15	0507 785	Retun tube
16	0507 783	Clip
17	0507 798	Suction tube
18	0508 343	Fitting
19	0508 239	Manometer
20	0558 483	Power cord
21	0551 714	Cord grip (2)*
22	0558 597	Bracket*
23	0551 980	Lock nut (2)*
24	0555 484	Screw (6)*
25	9800 340	Ground screw (2)*
26	0522 424	EMI filter, 20A*
27	0558 600	Power cord jumper*
28	5006 536	Filter

* UK only

BS4343

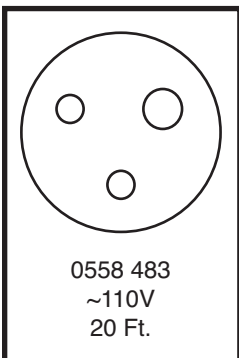

NEMA 5-15P

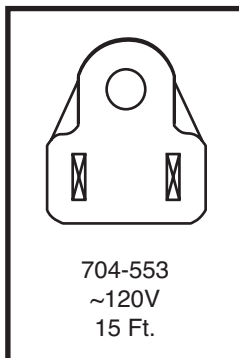

Spare parts list

Performance Series 1150e

Drive Assembly

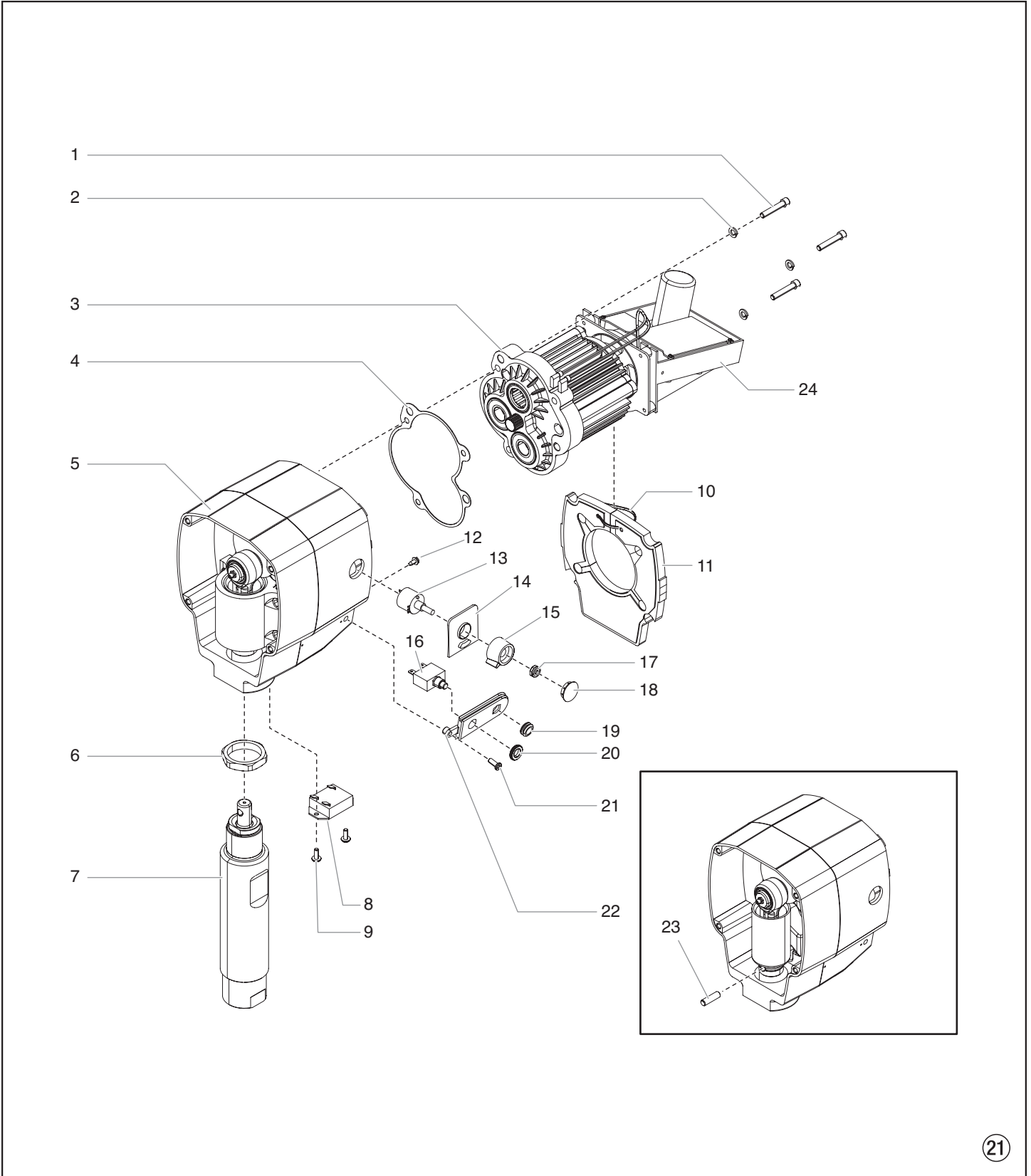

Item	Part No.	Description
1	0507 770	Screw (3)
2	9821 503	Washer (3)
3	0551 777	Motor (without electronic pressure control), 120V
4	0507 776	Housing gasket
5	0558 350A	Gearbox assembly
6	0507 773	Jam nut
7	0552 155A	Fluid section assembly
8	800-038	Starter motor
9	0507 760	Screw (2)
10	700-742	Tie wrap
11	800-433	Baffle assembly
12	9800 340	Ground screw
13	800-277	Potentiometer
14	800-293	Potentiometer mount
15	0507 740	Knob
16	762-327	Circuit breaker (includes item 20)
17	0507 749	Nut with seal
18	0507 748	Cap
19	0507 757	Grommit
20	-----	Nut
21	0507 756	Screw
22	800-075	Mounting plate
23	0507 777	Connecting pin
24	0551 788	Electronic pressure control, 120V

Spare parts list

Performance Series 1150e

Fluid section

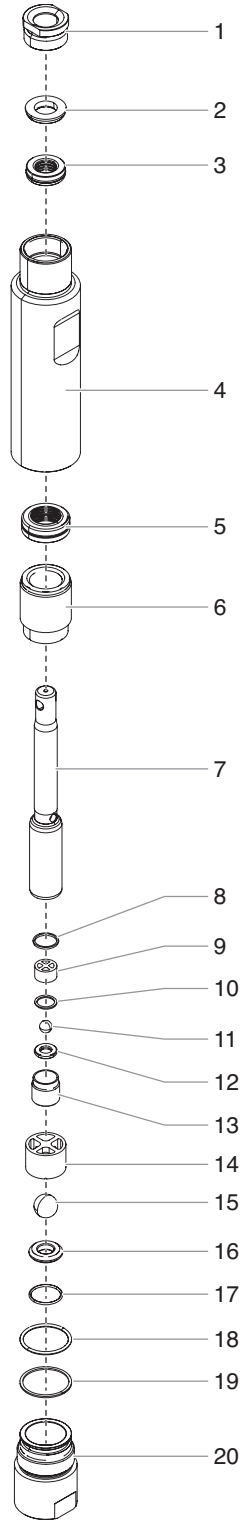

Item	Part No.	Description
1	0508 707	Retainer
2	0508 708	Spacer
3	-----	Upper packing
4	0552 156	Cylinder
5	-----	Lower packing
6	0552 157	Adapter
7	800-301	Piston rod
8	0507 734	Upper seal
9	0507 452	Upper ball guide
10	0507 454	Washer
11	9841 502	Outlet valve ball
12	0294 516	Outlet valve seat
13	0507 733	Outlet valve retainer
14	0507 729	Lower ball guide
15	51519	Inlet valve ball
16	00310	Inlet valve seat
17	0509 582	O-ring, Teflon
18	0507 729	O-ring
19	0507 730	Inlet valve seal
20	0507 728	Inlet valve housing
	0507 229	Piston assembly (includes items 7-13)
	0551 687	Repacking kit (includes items 2-3, 5, 8, 10-11, 15 and 17-19)
	0552 150	Lower packing insertion tool

Spare parts list

Performance Series 1150e

Gearbox assembly

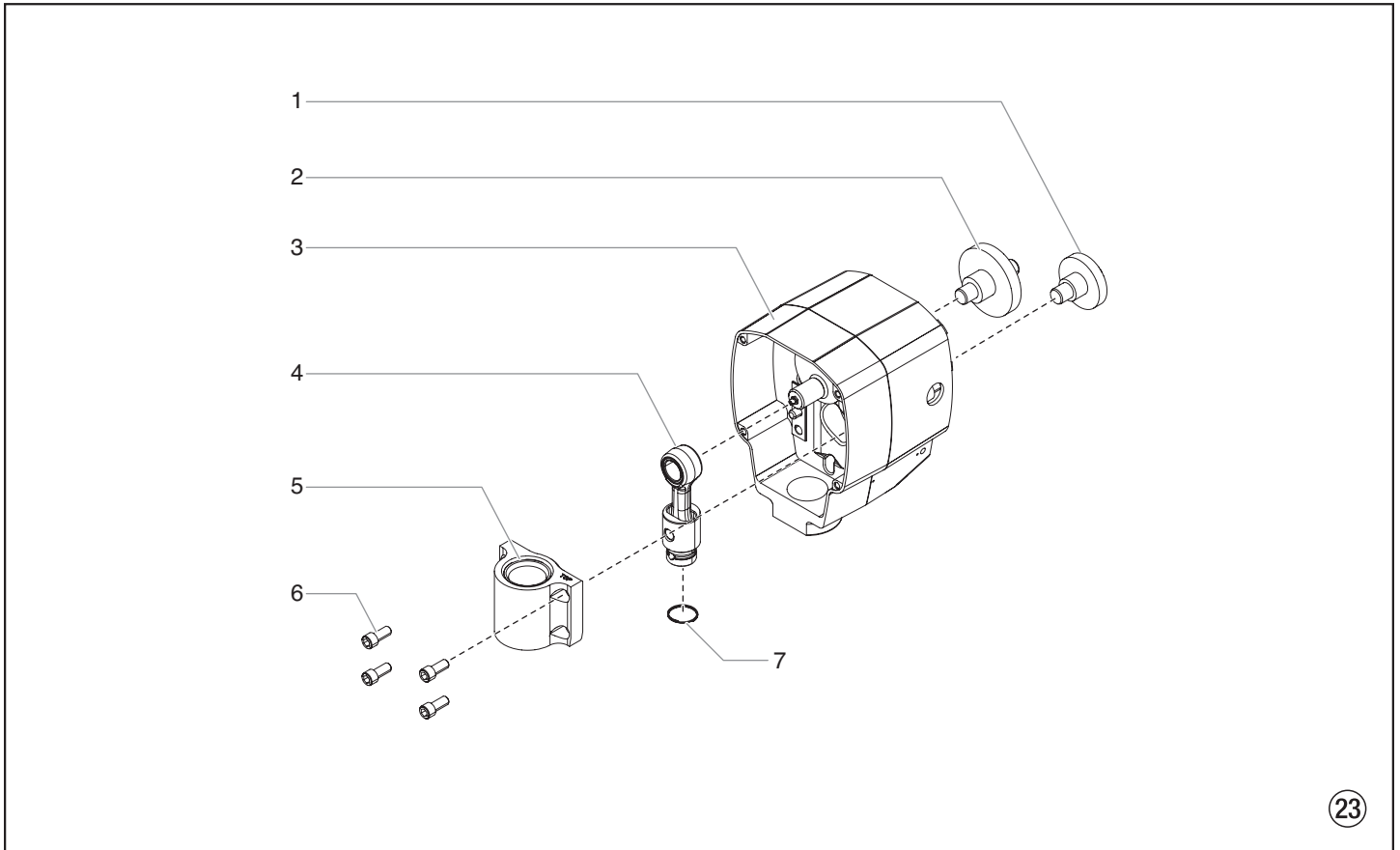

Item	Part No.	Description
1	800-261	1st stage gear
2	800-262	2nd stage gear
3	0507 220	Front gearbox assembly
4	800-510A	Slider assembly
5	0507 769	Slider housing
6	0507 767	Screw (4)
7	0507 768	Retaining ring

Spare parts list

Performance Series 1150e

Filter assembly

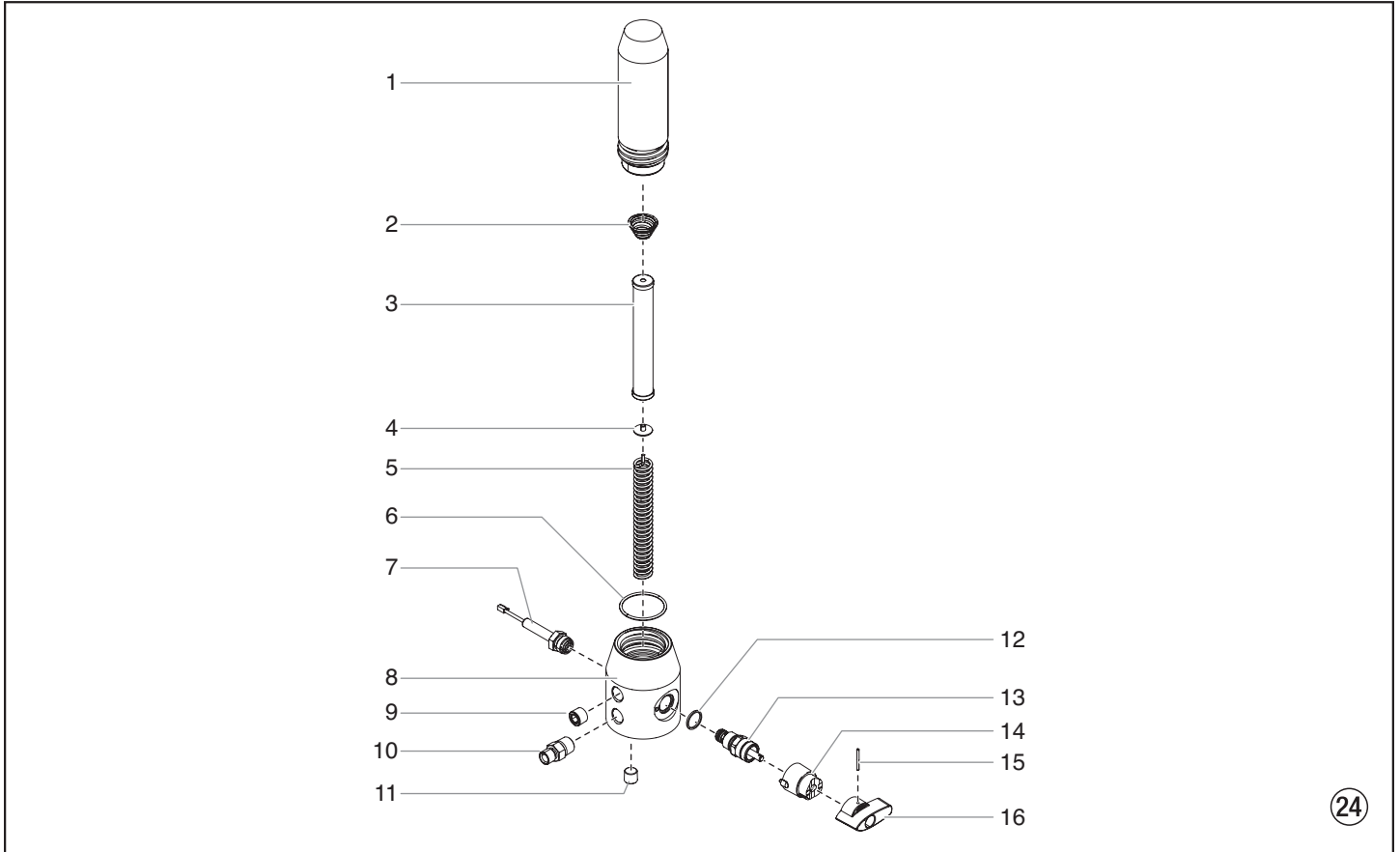

24

Item	Part No.	Description
1	0524 918	Filter housing
2	14058	Conical spring
3	0508 748	Filter
4	0508 603	Bearing ring
5	0508 749	Bearing spring
6	0551 951	O-ring
7	0524 917	Transducer assembly
8	0555 625	Transducer housing
9	0507 739	Pipe plug
10	0088 162	Fitting
11	0507 738	Pipe plug
12	0507 745	Gasket
13	0507 690	Bypass valve assembly
14	0507 931	Cam base
15	5006 543	Groove pin
16	0507 662	Relief valve knob

Spare parts list

Performance Series 1150e

Upright cart assembly

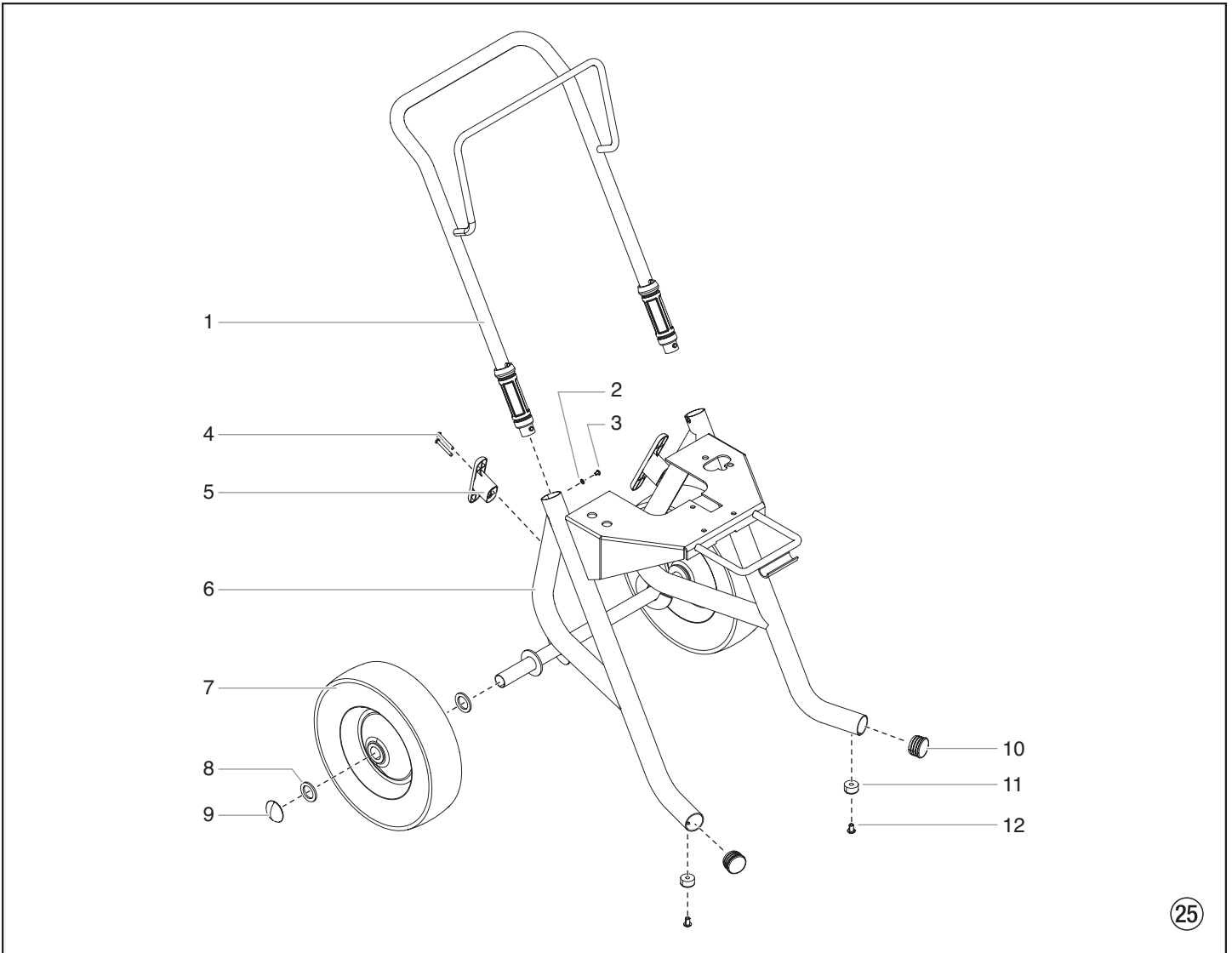

Item	Part No.	Description
1	0507 766	Handle assembly (includes items 2-3)
2	0509 386	Washer (4)
3	0295 608	Screw (2)
4	0507 774	Screw (4)
5	0507 655	Cord wrap (2)
6	0558 594	Cart weldment
7	0507 379	Wheel (2)
8	0294 534	Spacer (4)
9	9890 104	Axle cap (2)
10	9885 571	Plug (2)
11	13538	Bumper (2)
12	54458	Screw (2)

Warranty

Titan Tool, Inc., ("Titan") warrants that at the time of delivery to the original purchaser for use ("End User"), the equipment covered by this warranty is free from defects in material and workmanship. With the exception of any special, limited, or extended warranty published by Titan, Titan's obligation under this warranty is limited to replacing or repairing without charge those parts which, to Titan's reasonable satisfaction, are shown to be defective within twelve (12) months after sale to the End User. This warranty applies only when the unit is installed and operated in accordance with the recommendations and instructions of Titan.

This warranty does not apply in the case of damage or wear caused by abrasion, corrosion or misuse, negligence, accident, faulty installation, substitution of non-Titan component parts, or tampering with the unit in a manner to impair normal operation.

Defective parts are to be returned to an authorized Titan sales/service outlet. All transportation charges, including return to the factory, if necessary, are to be borne and prepaid by the End User. Repaired or replaced equipment will be returned to the End User transportation prepaid.

THERE IS NO OTHER EXPRESS WARRANTY. TITAN HEREBY DISCLAIMS ANY AND ALL IMPLIED WARRANTIES INCLUDING, BUT NOT LIMITED TO, THOSE OF MERCHANTABILITY AND FITNESS FOR A PARTICULAR PURPOSE, TO THE EXTENT PERMITTED BY LAW. THE DURATION OF ANY IMPLIED WARRANTIES WHICH CANNOT BE DISCLAIMED IS LIMITED TO THE TIME PERIOD SPECIFIED IN THE EXPRESS WARRANTY. IN NO CASE SHALL TITAN LIABILITY EXCEED THE AMOUNT OF THE PURCHASE PRICE. LIABILITY FOR CONSEQUENTIAL, INCIDENTAL OR SPECIAL DAMAGES UNDER ANY AND ALL WARRANTIES IS EXCLUDED TO THE EXTENT PERMITTED BY LAW.

TITAN MAKES NO WARRANTY AND DISCLAIMS ALL IMPLIED WARRANTIES OF MERCHANTABILITY AND FITNESS FOR A PARTICULAR PURPOSE WITH RESPECT TO ACCESSORIES, EQUIPMENT, MATERIALS OR COMPONENTS SOLD BUT NOT MANUFACTURED BY TITAN. THOSE ITEMS SOLD, BUT NOT MANUFACTURED BY TITAN (SUCH AS GAS ENGINES, SWITCHES, HOSES, ETC.) ARE SUBJECT TO THE WARRANTY, IF ANY, OF THEIR MANUFACTURER. TITAN WILL PROVIDE THE PURCHASER WITH REASONABLE ASSISTANCE IN MAKING ANY CLAIM FOR BREACH OF THESE WARRANTIES.

Note on disposal:

In observance of the European Directive 2002/96/EC on waste electrical and electronic equipment and implementation in accordance with national law, this product is not to be disposed of together with household waste material but must be recycled in an environmentally friendly way!



Titan or one of our dealers will take back your used Titan waste electrical or electronic equipment and will dispose of it for you in an environmentally friendly way. Please ask your local Titan service centre or dealer for details or contact us direct.

TITAN™

International

www.titantool.com/international

1770 Fernbrook Lane
Minneapolis, MN 55447